



TWO10+

LOCK FOR 2 SLIDING GLASS DOORS

The TWO secures two sliding doors at the same time. The lock parts are installed on the inside furniture panels where the two sliding doors meet. When unlocked the sliding doors can move freely past each other. Once the sliding doors are closed the two lock parts come together and lock automatically. The TWO secures your sliding doors in a sleek, unobtrusive way.

Useful at:

- Glass sliding doors
- Maximum 2 doors

Technology:

- RFID 125 kHz (EM4102 / EM4200)
 - up to 30 mm with RFID key cards
 - up to 15 mm with RFID key chips
- RFID 13.56 MHz (Mifare ISO 14443A)
 - up to 20 mm with RFID key cards
 - up to 10 mm with Mifare debit and credit cards
 - up to 15 mm with RFID key chips

Features:

- Battery driven (with 'battery low' alarm)
- Up to 20,000 cycles per battery
- Programmable without any pc or software
- Simple to install
- Range of temperature: 5 - 35°C
- Access control with a programming card for up to 49 users.

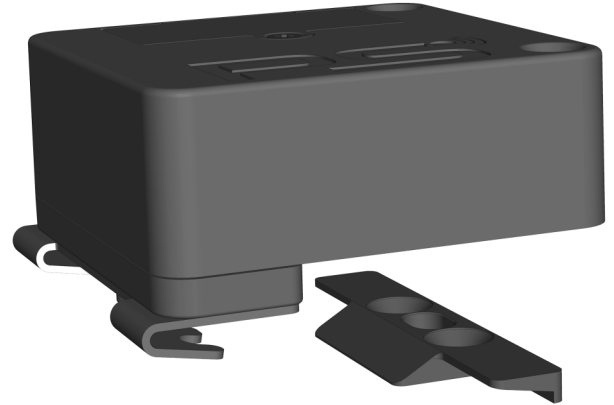

SPECIFICATION

The total distance is calculated by thickness of the door + distance between the doors.

The Package includes:

- lock
- adhesive tape for the lock
- locking part

UV glue to mount the latch on the glass is not included

Variations:

- Two10+ = for 10 mm total distance

Article number:	TWO 125 10+ / TWO 13 10+
Customs tariff number:	83013000
Order quantity:	100
Country of origin:	Austria



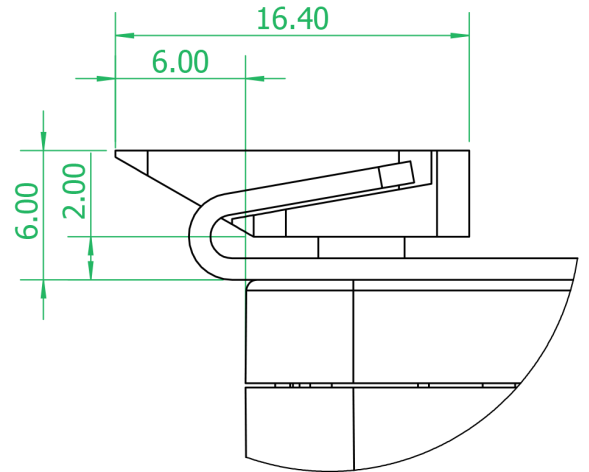
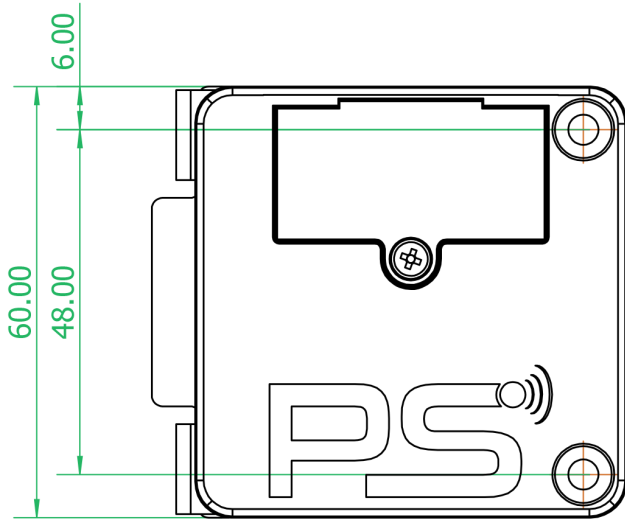

DETAIL A

